



YANMAR

COMPACT TRACTORS

22-60HP





For all seasons, and all reasons

With a comprehensive range covering the 22 to 60 HP class, Yanmar has a tractor to suit your industry, your application, and your budget.

A history of innovation

More than 100 years of Japanese innovation and excellence and some 50 years of European experience combines to provide a tractor range that is purpose-built for European customers.

The quality built into every Yanmar compact utility tractor is a reflection of the company's heritage.

Built in Japan to meet the specific needs and demands of European customers, these tractors are the

culmination of a continuous design and development process that is never satisfied and that is constantly evolving and improving.

These machines feature advanced systems and yet are easy to operate. They are quiet and clean-running, yet powerful and productive. And they set new standards whilst drawing inspiration from the company's proud past.



- Purpose-built for European customers
- Building on more than a century of innovation and excellence

“When only the best will do.”

“It’s all about trust. The landscapers and municipalities who are my professional customers want their tractors to complete the job. Always and under all circumstances. That is what YANMAR tractors do. They keep the promise.”



Mr. Karsten Kreibohm, owner of Kreibohm Kommunaltechnik, Alferde, Lower Saxony, Germany

YANMAR Tractor power range



SA222-R
SA222-Q



YT235-R
YT235-Q

22 HP

26 HP

35 HP

SA326-R
SA326-Q

SA426-R
SA426-Q



R = ROPS
Q = CABIN



YT347-R
YT347-Q



YT359-R
YT359-Q

55 HP

47 HP

60 HP



YM347-R



YM359-R

When the going gets tough...

With their compact dimensions, comfortable cab and intuitive operation, Yanmar's range of compact utility tractors are suitable for a huge range of industries, applications and terrains.



SA Series

SA222-R/SA222-Q

SA326-R/SA326-Q

SA426-R/SA426-Q

Exceptional ground clearance provides a smooth ride in all terrains.



ROPS

Provides excellent protection together with a low-profile for transportation.

Compact body

Designed to go anywhere and to operate where space is at a premium.

Spacious cab

Providing the ideal combination of operator comfort and operator protection.



Versatile category 3-point hitch

The machine is equipped with a Category I 3-point hitch as standard, and is offered with a wide array of attachments for maximum operating versatility and optimum utilisation levels.

Class leading fuel economy

Advanced engine and transmission technology combines to reduce fuel consumption and lower operating costs.



Specifications

Model	SA222 (Cabin & ROPS)	SA326 (Cabin & ROPS)	SA426 (Cabin & ROPS)
Output	22 HP	26 HP	26 HP
Transmission	Two pedal hydrostatic transmission		
Travelling speed	13 km/h	23 km/h	23 km/h
Lifting Capacity	520 kg	713 kg	713 kg
Short turning radius	2,4 m	2,6 m	2,6 m

YT2 Series

YT235-R/YT235-Q

Expect more. Get More. YT2 tractor delivers.



1350 mm



3063 mm

2060 mm

YT2 tractors were designed and developed to be a “pleasure to own”. And that is precisely what Yanmar has achieved.

Width and height may vary, based on tire type



Common rail STAGE V engine

Satisfies all current emissions regulations and is ready for EU Stage V standards.

HTS operation variable to max. speed of 31 km/h

Smooth speed and directional changes, easy switching between 2WD and 4WD, and an impressive top speed of 31 km/h.

Intuitive operation

Ergonomic controls are within easy reach and are intuitive to operate, allowing the driver to remain relaxed while working.

6000h DPF maintenance interval - the entire lifetime of the tractor

Automatically-regenerating diesel particulate filter reduces exhaust emissions for clean running and extended service life.

Drive over the mid-mower

Mid-mounted mower provides optimum combination of power, performance and operator visibility for increased production and safety.



Specifications

Model	YT235 (Cabin & ROPS)
Output	35 HP
Transmission	Two pedal hydrostatic transmission
Travelling speed	31 km/h
Lifting capacity	1300 kg
Cabin height	2060 mm

*Customer needs and expectations
lie at the very heart of the design of
the new YT2 Series*



35 HP

YT2 Series



***Giving farmers control,
whether they're on
the tractor or off it!***



Built today for the challenges of the future

Engine

Powerful and field proven Yanmar direct-injection TNV common rail engine utilises electronics to optimise combustion by electronically controlling fuel injection for reduced fuel consumption and lower running costs.

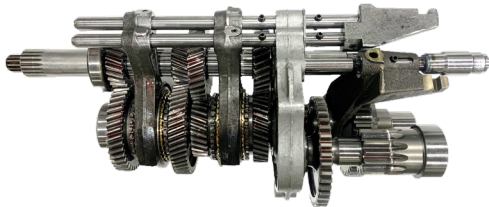
**Transmission**

Fully-synchronised 12 x 12 transmission provides smooth speed shifting throughout the range. Two or four-wheel drive is selected using a simple lever.

Simple to operate yet covered by state-of-the-art telematics, YM3 tractors combine tradition with technology to satisfy customer needs.

**Compact Dimensions**

Width of just 1,42 m with narrow tyre option and foldable ROPS protection provides go-anywhere, operate-anywhere flexibility.

Specifications

Model	YM347 (ROPS)	YM359 (ROPS)
Output	47 HP	60 HP
Transmission	Full synchronized gear	
Engine	STAGE V Common rail, 4 cylinder	
ROPS	Foldable	
Minimum width	1420 mm	1420 mm

YT3 Series

YT347-R/YT347-Q

YT359-R/YT359-Q

Highly efficient variable transmission i-HMT (integrated Hydro-Mechanical Transmission)

i-HMT achieves smooth and step-less gear shifting from zero to maximum speed. Optimum speeds that were not previously available with existing equipment are now selectable at will to match specific duties and applications.

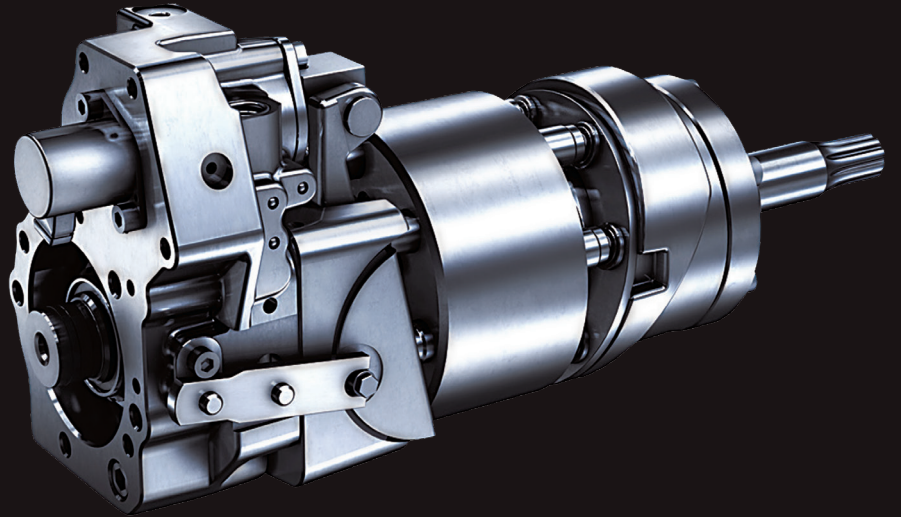

Fully flat deck

Unevenness is eradicated from the floor to create a level surface free from trip hazards for enhanced safety and comfort.



Full LCD display with Electronic controls

Instrumentation panel displays a reminder for key operations and maintenance intervals.

Vibration absorbing frame structure

Frame structure suppresses both noise and vibration to provide operator with ideal working environment and noise levels of just 77 dB(A).

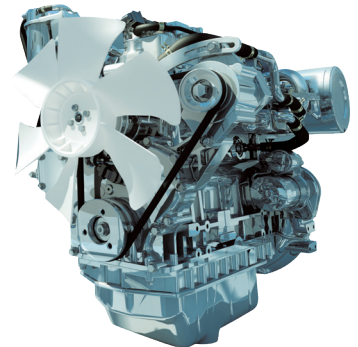

Only 77dB

High power common rail engine

Class-leading levels of power and productivity balanced by environmental credentials that are unmatched in this tractor weight class.

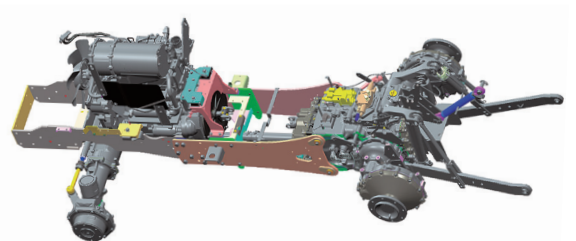

Specifications

Model	YT347 (Cabin & ROPS)	YT359 (Cabin & ROPS)
Output	47 HP	60 HP
Transmission	i-HMT hydro mechanical transmission	
Engine	STAGE V Common rail, 4 cylinder	
Sound	77dB	
Short turning radius	2,8 m	2,9 m

47-60 HP



Power to perform

The first tractor with i-HMT transmission under 50HP sets a new standard in the compact utility tractor sector.

YT3 Series

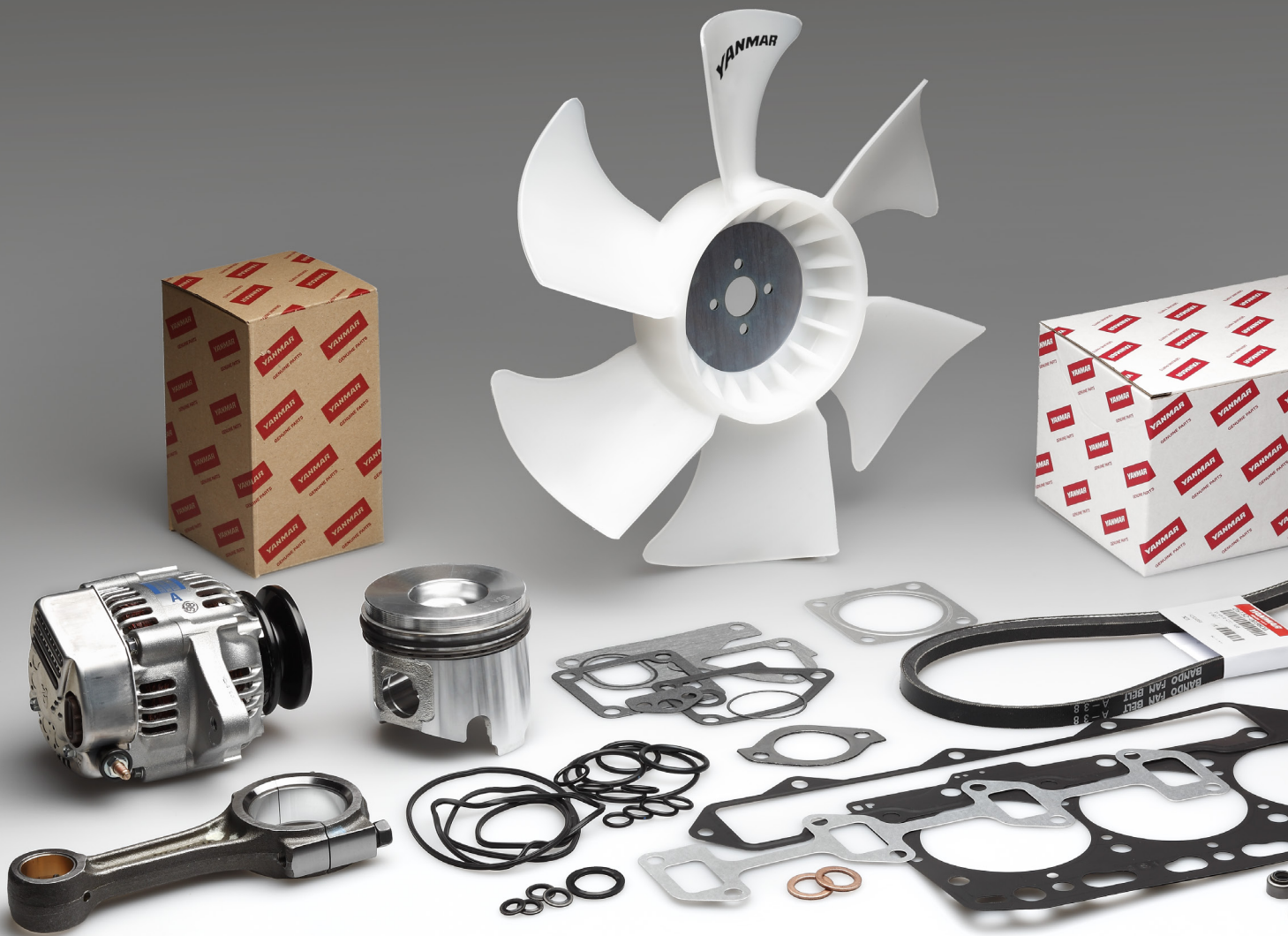

Yanmar 5 Year Warranty



Don't settle for standard. Yanmar tractors are designed from the ground up and backed by 110+ years of experience. This exceptional quality gives Yanmar the confidence to offer not 2, 3 or 4 but a 5-year or 5,000-hour warranty.

Yanmar Europe's unique in-house designed warranty ensures that any issue, normally covered by Yanmar's standard 2-year warranty, is covered by 5 years or 5,000 hours, whichever comes first.

What's included?

- ✓ Exterior, Cabin and ROPS
- ✓ Common rail diesel engine aftertreatment system
- ✓ Hydraulics system
- ✓ Engine parts with a 2-year warranty are extended to 5
- ✓ Transmissions parts such as: front axle, main transmission and driveline

Yanmar Genuine Parts

Yanmar's genuine parts are built, tested and produced to provide optimum safety and quality. By using genuine Yanmar spare parts, the performance, durability and resale value of your machine is assured.

Fast delivery of European parts distribution

The purpose-built Yanmar European bonded-goods central warehouse in The Netherlands dispatches stock items across Europe. The warehouse operates with a highly efficient, computer-controlled system that is fully integrated with Yanmar's (in-house designed) Parts Management System.





Yanmar Service Kits

Scan for more information.



All-inclusive peace of mind.

Quick and hassle-free maintenance with a full range of all-inclusive service kits for each tractor model. Service kits save time and money when servicing Yanmar tractors while offering an attractive price advantage. The maintenance kits contain all necessary Genuine Yanmar parts and components, manufactured according to the highest Yanmar standards.

For optimal performance, service intervals have been further optimized to 50, 250, 500 hours or after 1 or 2 years.



Genuine Yanmar Lubricants

The finest tractors deserve the finest lubricants.

Because Genuine lubricants and coolant are so important for engine performance, proper maintenance and valid warranty, Yanmar recommends SAE10W30 premium diesel oil for its tractors, equipped with Stage V engines.

Our Genuine lubricants offer low temperature protection against wear and are formulated for optimum DPF life.

Available in bottles of 5L, 20L and 208L drum, the volumes suit the farmers and are loved by service shops.



Specifications

MODEL		SA222-R (SA222-Q)	SA326-R (SA326-Q)	SA426-R (SA426-Q)	
ENGINE					
Engine name		3TNM72-DRE	3TNM72-DRE	3TNM72-DRE	
Engine power (unece reg. No 120)	kW	16,1	18,9	18,9	
Engine power	hp	22,0	26,0	26,0	
Number of cylinders		3	3	3	
Size of engine	ccm	903	1.115	1.115	
Torque	nm	55,7	67,8	67,8	
Engine speed	1/min	3.235	3.210	3.210	
Alternator	a	12V/55	12V/55	12V/55	
Battery	ah	12V/54	12V/54	12V/54	
TRAVELLING SECTION					
Transmission type		Hydrostatic	Hydrostatic	Hydrostatic	
Brake system		Multiple wet brake disk	Multiple wet brake disk	Multiple wet brake disk	
Drive		Selectable 4WD	Selectable 4WD	Selectable 4WD	
Differential lock		*	*	*	
Turning circle (inner radius)	mm	2.400	2.600	2.600	
Number of ranges		2	2	2	
Max. Speed (*highest gear)	km/h	13,0 (13,2)	23,3	23,3	
Towing capacity - not brokened	kg	700	700	700	
Towing capacity - brokened	kg	1.600	1.600	1.600	
Front axle load max.	kg	700	740	740	
Rear axle load max.	kg	1.000	1.000	1.000	
Max. Allowed weight	kg	1.475 (1.700)	1.475 (1.740)	1.475 (1.740)	
PTO power rear	kW	11,0	14,5	14,5	
Rear PTO, speed	1/min	540	540	540	
Rear-PTO	Type	1 3/8, 6 splines	1 3/8, 6 splines	1 3/8, 6 splines	
Mid. PTO speed	1/min	2.000	2.000	2.000	
Front-PTO: speed	1/min	2.000	1.000	1.000	
Front-PTO: 2000 1/min, 1, 15 splines		Option	Option	Option	
Fuel tank capacity	l	23	23	23	
Hydraulic oil tank capacity	l	15	15	15	

R = ROPS
Q = CABIN

	YM347-R	YM359-R	YT235-R (YT235-Q)	YT347-R (YT347-Q)	YT359-R (YT359-Q)
	4TNV88C	4TNV98C	3TNV88C	4TNV88C	4TNV98C
	35,0	43,9	25,5	34,3	43,9
	47,0	59,7	35,0	47,0	60,0
	4	4	3	4	4
	2.189	3.319	1.642	2.189	3.318
	142,6	205,0	105,4	140,4	199,0
	2.800	2.500	2.800	2.800	2.500
	12V/55	12V/55	12V/40 (12V/55)	12V/55	12V/55
	12V/70	12V/70	12V/51	12V/70	12V/80
	Mechanical full synchronized	Mechanical full synchronized	Hydrostatic	i-HMT	i-HMT
	Multiple wet brake disk	Multiple wet brake disk	Multiple wet brake disk	Multiple wet brake disk	Multiple wet brake disk
	Selectable 4WD	Selectable 4WD	Selectable 4WD	Selectable 4WD	Selectable 4WD
	*	*	*	*	*
	Left: 4.720 / Right: 4.760	Left: 4.720 / Right: 4.760	2.900	2.920	2.920
	12F+12R (incl. creep)	12F+12R (incl. creep)	3	3	3
	25,9	25,9	29,7	31,0	31,0
	3.000	3.000	2.000	1.500	1.500
	6.000	6.000	2.500	6.000	6.000
	1.600	1.600	980	1.600	1.600
	2.800	2.800	1.800	2.300	2.300
	3.660	3.660	2.135 (2.300)	3.185 (3.675)	3.185 (3.675)
	26,5	34,0	20,9	26,0	33,4
	540 / 750 RPM@ 2430 min ⁻¹	540 / 750 RPM@ 2430 min ⁻¹	540	540 / 750	540 / 750
	1 3/8, 6 splines	1 3/8, 6 splines	1 3/8, 6 splines	1 3/8, 6 splines	1 3/8, 6 splines
	NA	NA	Option (2000)	NA	NA
	NA	NA	1.000	1.000	1.000
	NA (After market)	NA (After market)	Option	Option	Option
	48	48	27	48	48
	29	29	31	29	29

Specifications are subject to change

Specifications

MODEL		SA222-R (SA222-Q)	SA326-R (SA326-Q)	SA426-R (SA426-Q)	
Steering system		Hydraulic powered	Hydraulic powered	Hydraulic powered	
Capacity hydro pump	l/min	28,3	28,3	28,3	
Steering pump	l/min	13,2	13,2	13,2	
Pump for hydraulics	l/min	15,1	15,1	15,1	
Hydraulic pressure	bar	130	167	167	
Hydraulic connections	nm	2 Sets	2 Sets	2 Sets	
3-POINT LIFT CAPACITY					
Rear	kg	510	713	713	
61 cm behind lift point - Rear	kg	397	548	548	
Front	kg	325	530	530	
61 cm behind lift point - Front	kg	280	425	425	
DIMENSIONS AND WEIGHT					
Total length	mm	2.699	2.793	2.793	
Total width	mm	1.198 (1.197)	1.436	1.436	
Ground clearance	mm	160	260	260	
Wheel base	mm	1.470	1.600	1.600	
Industrial wheel set r4 size: *2	inch	FT:18x8.50-10 RT: 26x12.00-12	FT: 23x8.50-12 RT: 12-16.5	FT: 23x8.50-12 RT:14-17.5	
Agri wheel set r4 size *2	inch	-	-	-	
Height	mm	1.515 (2.070)	1.675 (2.070)	1.675 (2.070)	
Weight	kg	768 (1.100)	846 (1.190)	846 (1.190)	
Midmower m60, width	m	188	188	188	
Midmower cutting width	cm	152 (151)	151	151	

*1 = Adjustable rim

*2 = More types available

R = ROPS
Q = CABIN

	YM347-R	YM359-R	YT235-R (YT235-Q)	YT347-R (YT347-Q)	YT359-R (YT359-Q)
	Hydraulic powered	Hydraulic powered	Hydraulic powered	Hydraulic powered	Hydraulic powered
	38,5	38,5	41,8	60,0	55,5
	21,5	21,5	15,3	21,7	20,1
	17,0	17,0	26,5	38,3	35,5
	167	167	167	167	167
	2 Sets	2 Sets	2 Sets	2 Sets	2 Sets
	1.450	1.430	950	1.660	1.660
	1.250	1.250	700	1.400	1.400
	NA	NA	430	850	850
	NA	NA	390	650	650
	3.715	3.715	3.063	3.355	3.355
	1.420 - 1.723 *1	1.420 - 1.723 *1	1.267	1.639 (1.569)	1.569 *1
	Min.227-Max.336	Min.227-Max.336	289	380	380
	1.970	1.970	1.650	1.927	1.967
	-	-	FT: 25x8.5-14 RT:15-19.5	FT: 10.00-16.5 RT: 17.5-24	FT: 10.00-16.5 RT: 17.5-24
	FT: R1, 200/70R16 (Radial Wide Low) RT: R1, 360/70R20 (Radial Wide Low)	FT: R1, 280/70R16 (Radial Wide High) RT: R1, 380/70R24 (Radial Wide High)	-	-	-
	2.380	2.380	2.442 (2.060)	2.450 (2.310)	2.450 (2.310)
	2.085	2.085	1.110 (1.280)	1.800 (1.960)	1.900 (2.150)
	NA	NA	188	NA	NA
	NA	NA	152	NA	NA

Specifications are subject to change

Your nearest Yanmar dealer

**Wherever you are, wherever you go,
wherever you work. Yanmar is right
there for you.**

Yanmar's European headquarters in the Netherlands supports a sales organisation covering the whole of Europe. Furthermore, the company's sales and service network operates in more than 130 countries.

www.yanmar.com/eu/dealerlocator

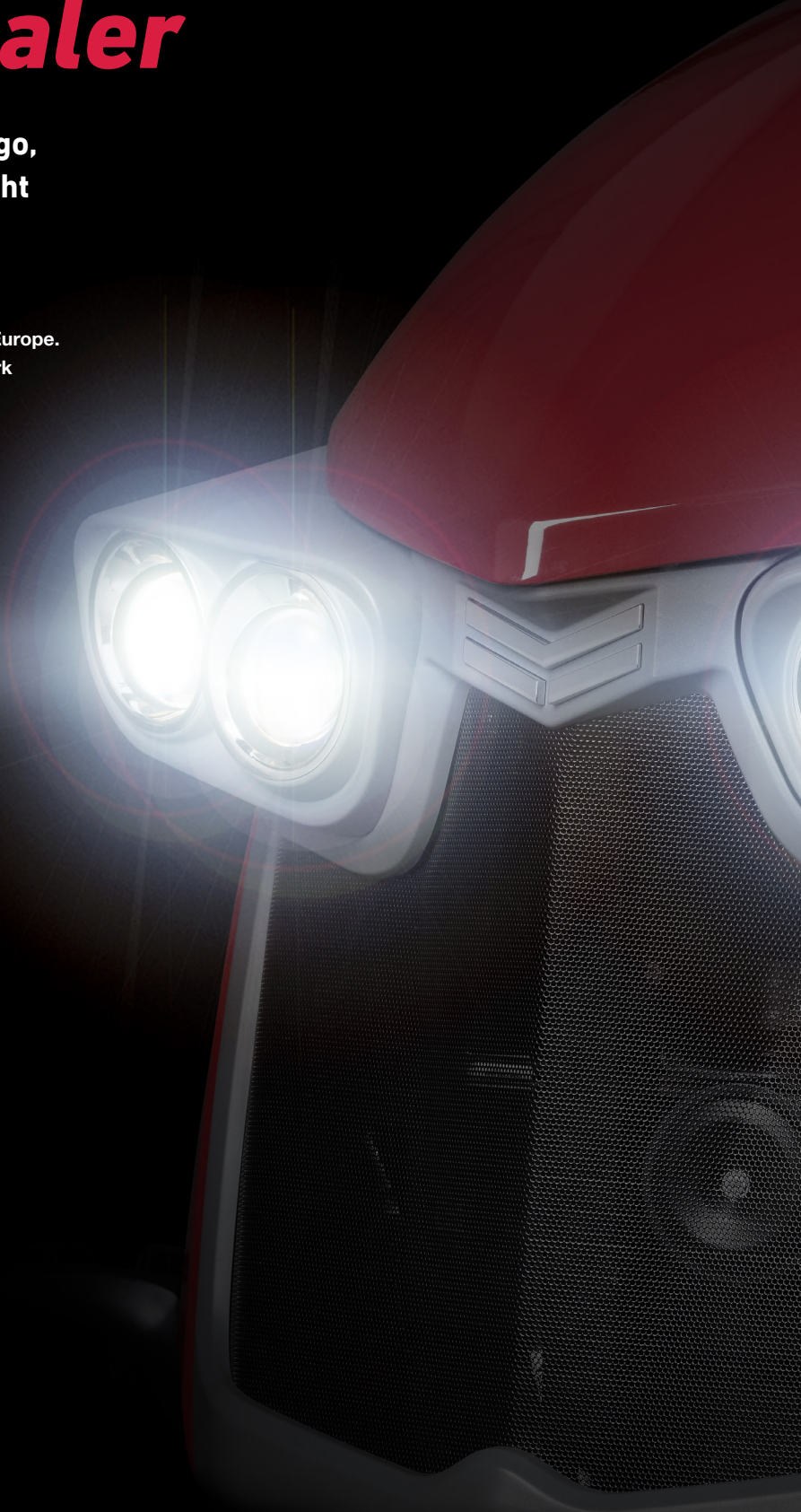





Regional Office / Sales & Service

Yanmar Europe B.V.
Brugplein 11, 1332 BS Almere, The Netherlands
T: +31 (0)36 549 3200
F: +31 (0)36 549 3209
E: agrienquiry-yeu@yanmar.com
www.yanmar.com/eu

Head Office

Yanmar Co., Ltd.
YANMAR FLYING-Y BUILDING
1-32 Chayamachi, Kita-ku,
530-8311 Osaka, Japan
www.yanmar.com